



**Combined Cutter/Vegetable slicer
Combined vegetable slicer/cutter
7l/7.4qt, variab.speed-1500w, nema
5-15p**

ITEM # _____
MODEL # _____
NAME # _____
SIS # _____
AIA # _____



602243 (DTRK70)

Combined Vegetable Slicer/Cutter Mixer angled front, continuous feed design, variable speed (300-3700 RPM), large single feed hopper, includes 7.4 qt stainless steel bowl.

Short Form Specification

Item No. _____

Vegetable Cutter/Mixer, angled front, continuous feed design, variable speed (300-3700 RPM), large single feed hopper, includes 7L/7.4QT stainless steel bowl, lid, bowl scraper, microtooth blade rotor, handle pusher, standard ejector, stainless steel feeding arm & hopper, aluminum motor housing, 1-1/3 HP, (discs NOT included)

Main Features

- 3 in 1 machine: cutter, emulsifier and vegetable slicer to slice, grate, liquidise, mix and mince in a matter of seconds.
- Incl system to incline motor base at 20° to better fit the vegetable slicer attachment.
- Long vegetables round hopper integrated in the feed arm, 3/4 moon roundish hopper to limit pre-cutting operations.
- Emulsifier function (scraper) included as standard.
- All parts in contact with food are removable without the use of tools, completely dismountable and dishwasher safe.
- Automatic restart of the machine with the 3/4 moon shaped pusher in position.
- Delivered with: 7.4qt (7lt) stainless steel cutter bowl, transparent lid, scraper and microtoothed blade rotor.
- Complete and wide selection of blades and grids available, Diameter of blades and grids are 8" (205mm).
- Vegetable slicer unit has slicing, grating, shredding (julienne) as well as dicing and french fries capabilities.
- Magnetic safety system and motor brake. Prevents machine from running when vegetable preparation lever and/or hopper are lifted or when cutter lid is not properly closed.
- Pulse function to coarse chopping.
- Automatic speed limitation according to the selected function (slicer or cutter).
- Base fixed cover for a better handling.

Construction

- Improved ventilation system to manage smoothly heavy duty use.
- Improved incl system for better stability.
- Improved fixing of long vegetable hopper pusher.
- Power: 1.3 HP.
- Vegetable cutting at 4 speeds up to 800 rpm. Food precessing at 10 variable speeds: 300-3700 rpm.
- TRK70 - 1.5 kW.
- Compact and portable design.
- Stainless steel bowl has a high chimney to ensure high productivity also when processing liquids (75% of the nominal capacity).

APPROVAL: _____

Combined Cutter/Vegetable slicer
Combined vegetable slicer/cutter 7l/7.4qt, variab.speed-1500w,
nema 5-15p



Combined Cutter/Vegetable slicer Combined vegetable slicer/cutter 7l/7.4qt, variab.speed-1500w, nema 5-15p

Included Accessories

- 1 of Lid and bowl scraper for 7.4 qts (7 L) cutter mixer PNC 650104
- 1 of Stainless steel bowl for 7.4 qts (7 L) cutter mixer PNC 653593
- 1 of Ejector disc PNC 653772
- 1 of Microtoothed blade rotor for 7 lt cutter mixer PNC 653874

Optional Accessories

- | | |
|---|---|
| <ul style="list-style-type: none"> • Stainless steel shredding disc with S-blades 5/32" x 5/32" (4x4 mm) PNC 650077 • Stainless steel shredding disc with S-blades 1/4"x 1/4" (6x6 mm) (can also be used for French fries) PNC 650078 • Stainless steel shredding disc with S-blades 5/16" x 5/16" (8x8 mm) (can also be used for French fries) PNC 650079 • Stainless steel shredding disc with S-blades 3/8" x 3/8" (10x10 mm) (can also be used for French fries) PNC 650080 • Stainless steel pressing/slicing disc with S-blades .6 mm (can be used for slicing or combined with grids) PNC 650081 • Stainless steel pressing/slicing disc with S-blades 1/32" (1 mm) (can be used for slicing or combined with grids) PNC 650082 • Stainless steel pressing/slicing disc with S-blades 5/64" (2 mm) (can be used for slicing or combined with grids) PNC 650083 • Stainless steel pressing/slicing disc with S-blades 1/8" (3 mm) (can be used for slicing or combined with grids) PNC 650084 • Stainless steel pressing/slicing disc with S-blades 5/32" (4 mm) (can be used for slicing or combined with grids) PNC 650085 • Stainless steel pressing/slicing disc with S-blades 3/16" (5 mm) (can be used for slicing or combined with grids) PNC 650086 • Stainless steel pressing/slicing disc with S-blades 1/4" (6 mm) (can be used for slicing or combined with grids) PNC 650087 • Stainless steel pressing/slicing disc with S-blades 5/16" (8 mm) (can be used for slicing or combined with grids) PNC 650088 • Stainless steel pressing/slicing disc with corrugated S-blades 5/64" (2 mm) (can be used for slicing or combined with grids) PNC 650089 • Stainless steel pressing/slicing disc with corrugated S-blades 1/8" (3 mm) (can be used for slicing or combined with grids) PNC 650090 | <ul style="list-style-type: none"> • Stainless steel pressing/slicing disc with corrugated S-blades 1/4" (6 mm) (can be used for slicing or combined with grids) PNC 650091 • Bistrot Pack, Stainless Steel Disc Set containing one each of: C2SX 5/64" (2mm) slicing disc, C5SX 3/16" (5mm) slicing disc, J2X 5/64" (2mm) grating disc PNC 650092 • Lid and bowl scraper for 7.4 qts (7 L) cutter mixer PNC 650104 • Set of 3 stainless steel discs for Pizza 5/64", 5/32", 9/32" (2mm and 4mm pressing/slicing discs with S-blades, 7mm grating disc) PNC 650107 • Cleaning tool for TRS, TRK & TR210 3/16-5/16-3/8 in (5-8-10 mm) dicing grids PNC 650110 • Dicing set 10X10X10MM (10mm aluminum slicing pressing disc with 205mm diam. and 10mm grid) PNC 650112 • Gastronomy Pack-set discs (2mm, 5mm and 10mm slicing pressing discs, 2mm grating disc, 4x4mm shredding disc, 10x10mm dicing grid) and grid cleaning tool PNC 650113 • Set of 7 discs (2mm, 5mm and 10mm slicing pressing discs, 2mm and 7mm grating discs, 4x4mm shredding disc, 10x10mm dicing grid) and grid cleaning tool PNC 650114 • Aluminum pressing/slicing disc with straight blades 10 mm - for dicing PNC 650115 • Aluminum pressing/slicing disc with straight blades 8 mm - for dicing PNC 650116 • Stainless steel shredding disc with S-blades 5/64" x 5/16" (2x8 mm) PNC 650158 • Stainless steel shredding disc with S-blades 5/64" x 3/8" (2x10 mm) PNC 650159 • Stainless steel pressing/slicing disc with S-blades 3/8" (10 mm) (can be used for slicing or combined with grids) PNC 650160 • Stainless steel pressing/slicing disc with S-blades 15/32" (12 mm) (can be used for slicing or combined with grids) PNC 650161 • Stainless steel pressing/slicing disc with corrugated S-blades 5/16" (8 mm) (can be used for slicing or combined with grids) PNC 650162 • Stainless steel pressing/slicing disc with corrugated S-blades 3/8" (10 mm) (can be used for slicing or combined with grids) PNC 650164 • Stainless steel pressing/slicing disc with S-blades 33/64" (13 mm) (can be used for slicing or combined with grids) PNC 650165 • Stainless steel shredding disc with S-blades 5/64"x 5/64" (2x2 mm) PNC 650166 • Stainless steel shredding disc with S-blades 1x8" x 1/8" (3x3 mm) PNC 650167 • Set of 4 Stainless Steel Discs containing one each of: C2S 5/64" (2mm) slicing disc, C5S 3/16" (5mm) slicing disc, J2X 5/64" (2mm) grating disc and J7X 9/32" (7mm) grating disc PNC 650178 |
|---|---|





**Combined Cutter/Vegetable slicer
Combined vegetable slicer/cutter
7l/7.4qt, variab.speed-1500w, nema 5-15p**

- Set of 7 Stainless Steel Discs containing one each of: C2S 5/64" (2mm) slicing disc, C5S 3/16" (5mm) slicing disc, J2X 5/64" (2mm), J7X 9/32" (7mm) grating disc, AS4X 5/32"x5/32" (4x4mm) shredding disc, C10PSB 3/8" (10mm) presser/slicer, MT10T 3/8"x3/8" (1 PNC 650179
- Stainless steel work table assembly. PNC 653283
- Dicing grid 3/16" x 3/16" (5x5 mm) PNC 653566
- Dicing grid 5/16" x 5/16" (8x8 mm) PNC 653567
- Dicing grid 3/8"x 3/8" (10x10 mm) PNC 653568
- Dicing grid 15/32"x 15/32" (12x12 mm) PNC 653569
- Dicing grid 25/32"x 25/32" (20x20 mm) PNC 653570
- Grid for chips 1/4" x 1/4" (6x6 mm) PNC 653571
- Grid for chips 5/16"x 5/16" (8x8 mm) PNC 653572
- Grid for chips 3/8" x 3/8" (10x10 mm) PNC 653573
- Stainless steel bowl for 7.4 qts (7 L) cutter mixer PNC 653593
- Support for 1 disc, diam. 175mm and 205mm PNC 653632
- Ejector disc PNC 653772
- Stainless steel grating disc 5/64", fine (2mm) PNC 653773
- Stainless steel grating disc, 1/8", fine (3mm) PNC 653774
- Stainless steel grating disc 5/32" (4mm) PNC 653775
- Stainless steel grating disc 9/32" (7mm) PNC 653776
- Stainless steel grating disc 11/32" (9mm) PNC 653777
- Stainless steel grating disc, designed for nuts, chocolate & bread crumbs, stainless steel PNC 653778
- Stainless steel grating disc, especially fine grating for Parmesan cheese and chocolate, stainless steel PNC 653779
- Set of 3 discs, diam. 205 mm (5mm slicer, 4mm grater, 6mm julienne/shredder) PNC 653869
- Set of 5 discs, diam. 205 mm (4mm and 6mm slicer, 6mm julienne/shredder, 5mm and 10 mm slicer, 10x10mm grid) PNC 653870
- SMOOTH BLADE ROTOR - 7L CUTTER-MIXER PNC 653881
- MICROTOOTHED BLADE ROTOR (EMULSIONS) - 7L CUTTER-MIXER PNC 653882





Combined Cutter/Vegetable slicer Combined vegetable slicer/cutter 7l/7.4qt, variab.speed-1500w, nema 5-15p

Front

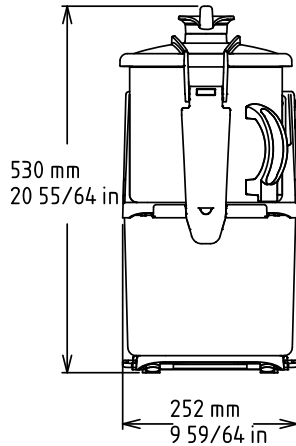

Side

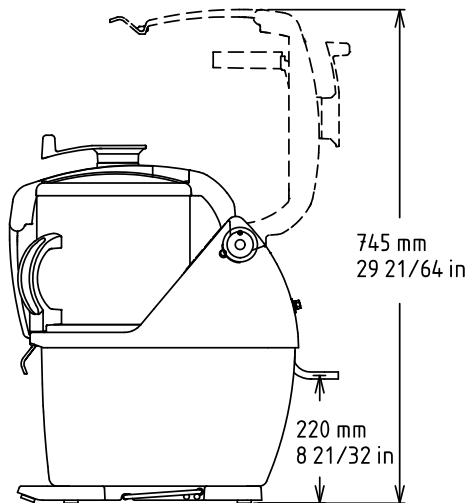

EI = Electrical connection

Top

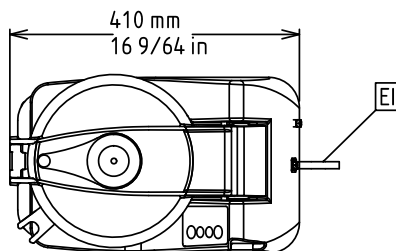

Electric

Supply voltage:

602243 (DTRK70)

110-120 V/1N ph/60 Hz

Total Watts:

1.5 kW

Plug type:

USA NEMA 5-15P

Key Information:

External dimensions, Width:

9 15/16" (252 mm)

External dimensions, Depth:

19 1/16" (485 mm)

External dimensions, Height:

19 7/8" (505 mm)

Shipping width:

13" (330 mm)

Shipping depth:

32 1/4" (820 mm)

Shipping height:

23 5/8" (600 mm)

Shipping weight:

71 lbs (32 kg)



Combined Cutter/Vegetable slicer
Combined vegetable slicer/cutter 7l/7.4qt, variab.speed-1500w, nema 5-15p
The company reserves the right to make modifications to the products without prior notice. All information correct at time of printing.

2024.12.21